

# A Guide to Aluminium Fencing

MARANO

LIGHT • STYLE • VISION



Connect in Grey Wood Effect with Palm Screen

All of our Marano® Integrated boards are made from

# 6063 T5 Grade Aluminium

As awareness has grown of the advantages to using aluminium in the construction of gates and railings, so has our range of extrusions. Marano® Integrated offers long lasting, lightweight aluminium boards with total flexibility.



Modular



Lightweight



Easy Assembly



Long Lasting





Parallel 100 in Pebble Grey between existing concrete posts



Scan here for  
FREE colour  
samples

# BOARD PROFILES & COLOURS

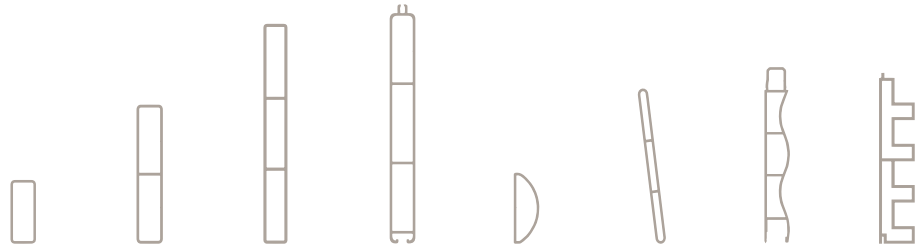

Parallel 50	Parallel 100	Parallel 150	Connect 150	Half Round	Louvre	Wave	Ridged
-------------	--------------	--------------	-------------	------------	--------	------	--------

Basalt Grey		✓	✓	✓	✓	✓	✓	✓
Beige Grey		✓	✓	✓	✓	X	X	X
Pebble Grey		✓	✓	✓	✓	X	X	X
Black Sand		✓	✓	✓	✓	✓	✓	✓
Oak Wood Effect		✓	✓	✓	✓	X	X	X
Grey Wood Effect		✓	✓	✓	✓	X	X	X
Mill Finish Board		✓	✓	✓	✓	✓	✓	✓

Mill finish boards can be used to powder coat to a RAL colour of your choice.





**ONE UNIVERSAL POST**



# INFINITE POSSIBILITIES

Below you can see how adding the various inserts will transform your standard mid post into a corner or end post, which will also allow you to build your fence using a mixture of boards, along with 2 and 5mm aluminium laser cut screens.

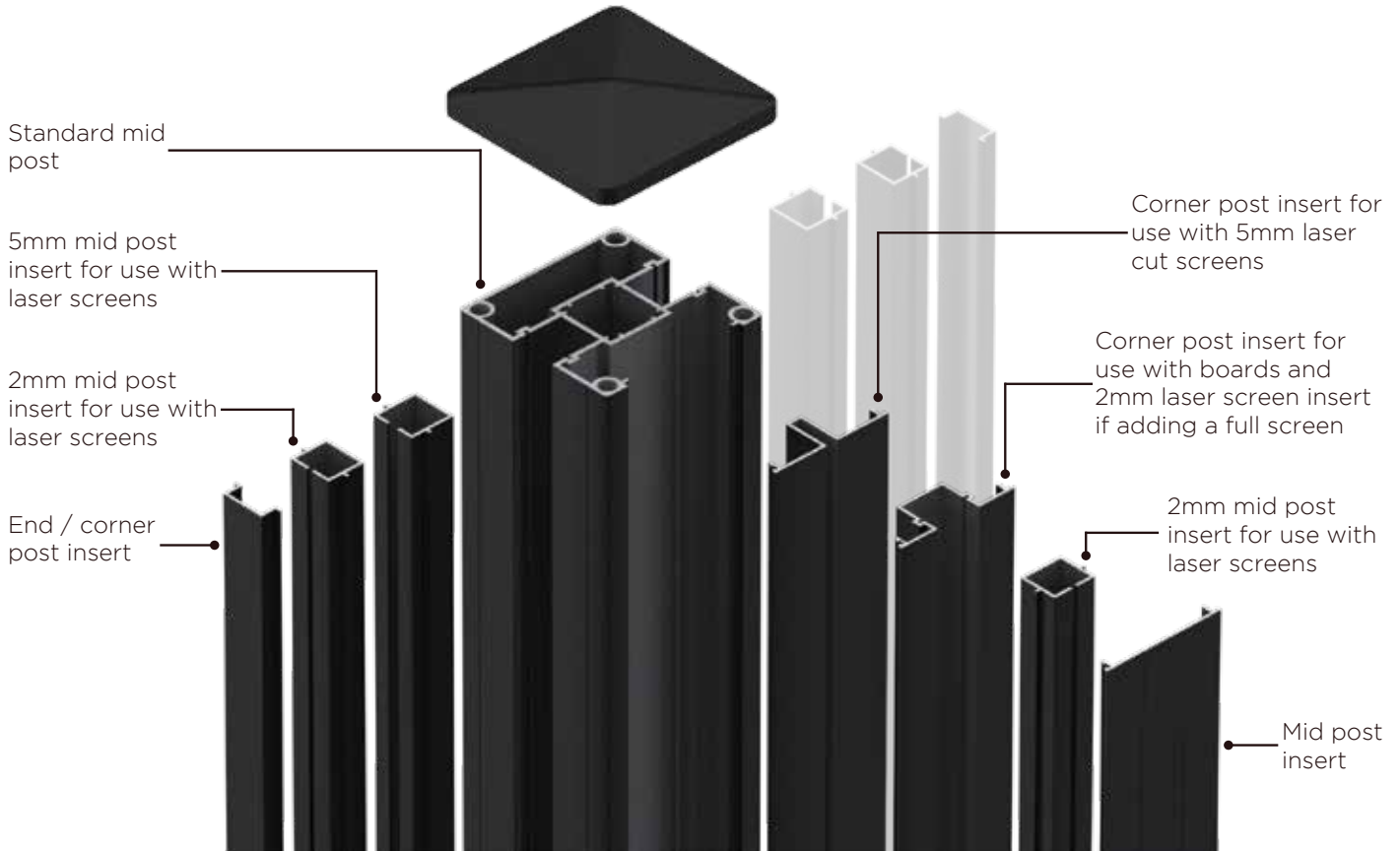



Parallel 100 in Basalt Grey



## FINISHES

- Black Sand
- Basalt Grey

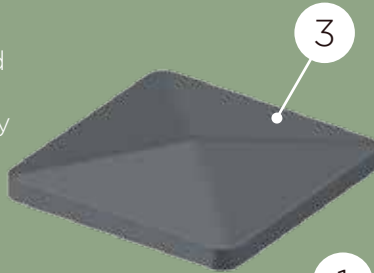

3

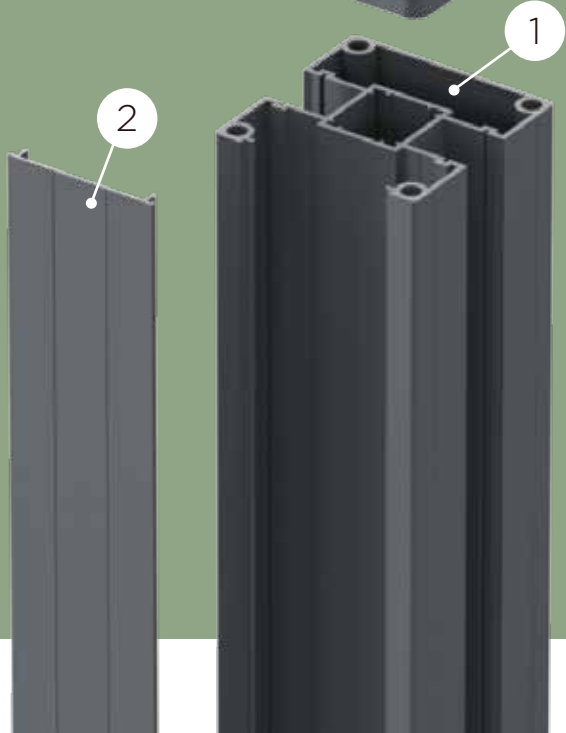

1

2

## UNIVERSAL POST

Our posts are supplied at 2.5m long for concreting into the ground. As standard they are designed to make a 1.8m fence height. They are supplied complete with the post extrusion (1), capping to hide the screws (2), and a plastic post cap (3). By adding the various inserts, you can create a mid, corner or end posts for use with boards and screens (see page 7 for inserts).



2500mm

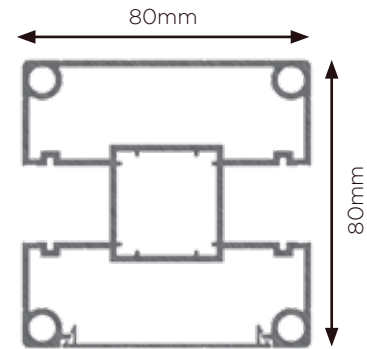

80mm

80mm

We supply handy sized 20kg bags of Post Concrete.





Woodland Screens with Half Posts

# CUTTING POSTS TO DIFFERENT HEIGHTS

You can create different height fences less than 1.8m high, by simply cutting the posts to your required height, to suit either a concrete-in or bolt-down system.

For cutting down posts, we recommend using a circular saw with an appropriate aluminium saw blade.

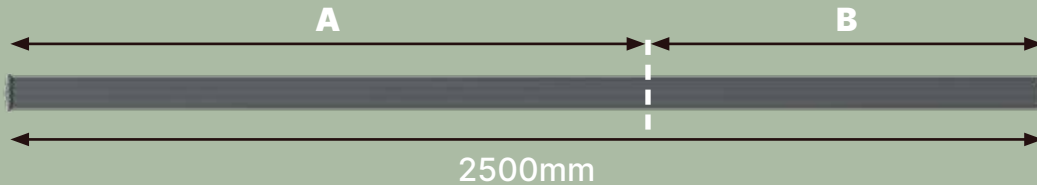

## HANDY TIP!



EACH SYSTEM HAS DIFFERENT HEIGHTS. FOR DIMENSIONS ON OUR CONCRETE-IN AND BOLT-DOWN SYSTEMS, PLEASE REFER TO THE CORRESPONDING TECHNICAL DRAWING FOUND ON OUR WEBSITE.

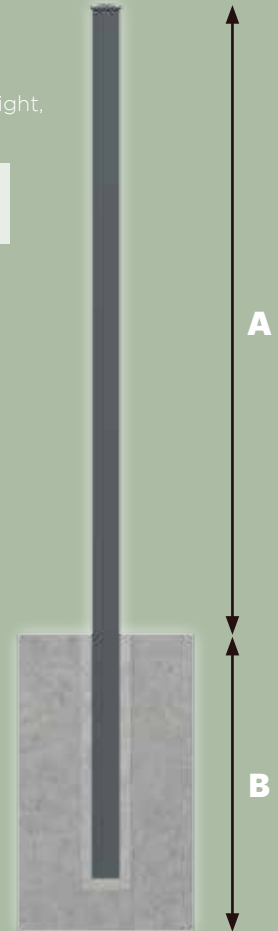



Parallel 50 in Beige Grey



# CREATING BOLT-DOWN POSTS

If your installation requires the use of bolt-down posts, simply cut the post to the desired height and attach the base plate using the four bolts (1) supplied with the base plate (2) and cover cap (3).

## FINISHES

 Black Sand

 Basalt Grey

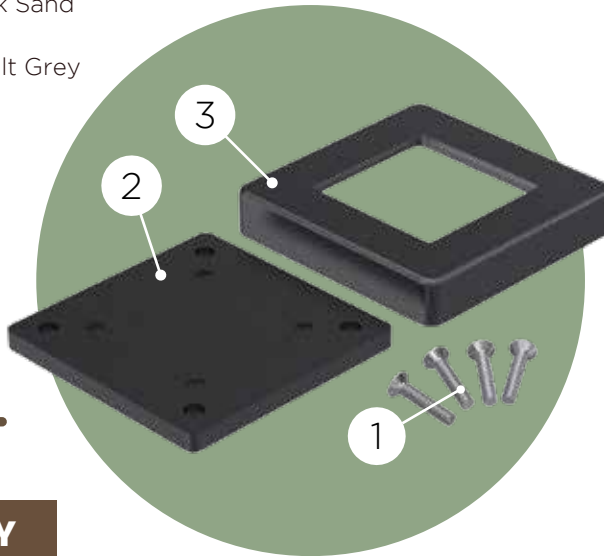

## HANDY TIP!

SLIDE THE BASE PLATE COVER CAP ONTO POST, BEFORE BOLTING ON THE BASE PLATE, TO SAVE SCRATCHING THE POST.

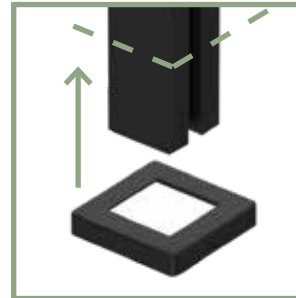

Cut post to desired length and thread on the base plate cover cap.



Fix the base plate to the post using the screws provided.



Secure the bolts but be sure not to overtighten.

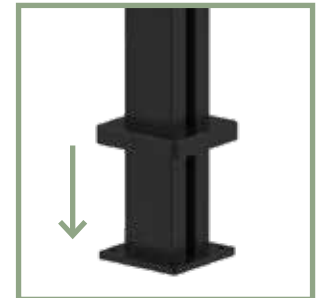

Slide the cover cap down onto the base plate.



Parallel 50 in Black Sand



# HOW DO THE SPACERS WORK?

Inserting spacers between each board creates an even space between Parallel 50, Parallel 100 and Half Round Boards. Available in Black Sand and Basalt Grey finish.



25mm



50mm



100mm



Connect in Beige Grey with Sunburst Screen



# CONNECT & LASER SCREENS



Our range of 2 and 5mm contemporary laser cut screens can be incorporated in with Marano® Integrated in several ways. Full height 1000mm width screens can be used in conjunction with all board styles. Whereas the 300mm high screens can be discretely integrated with the Connect 150 system. Screens are secured with the top and bottom fixings kits. The versatility of the screens allows them to be used alone, as trellis, or wall art.

## Fence panels using boards and screens

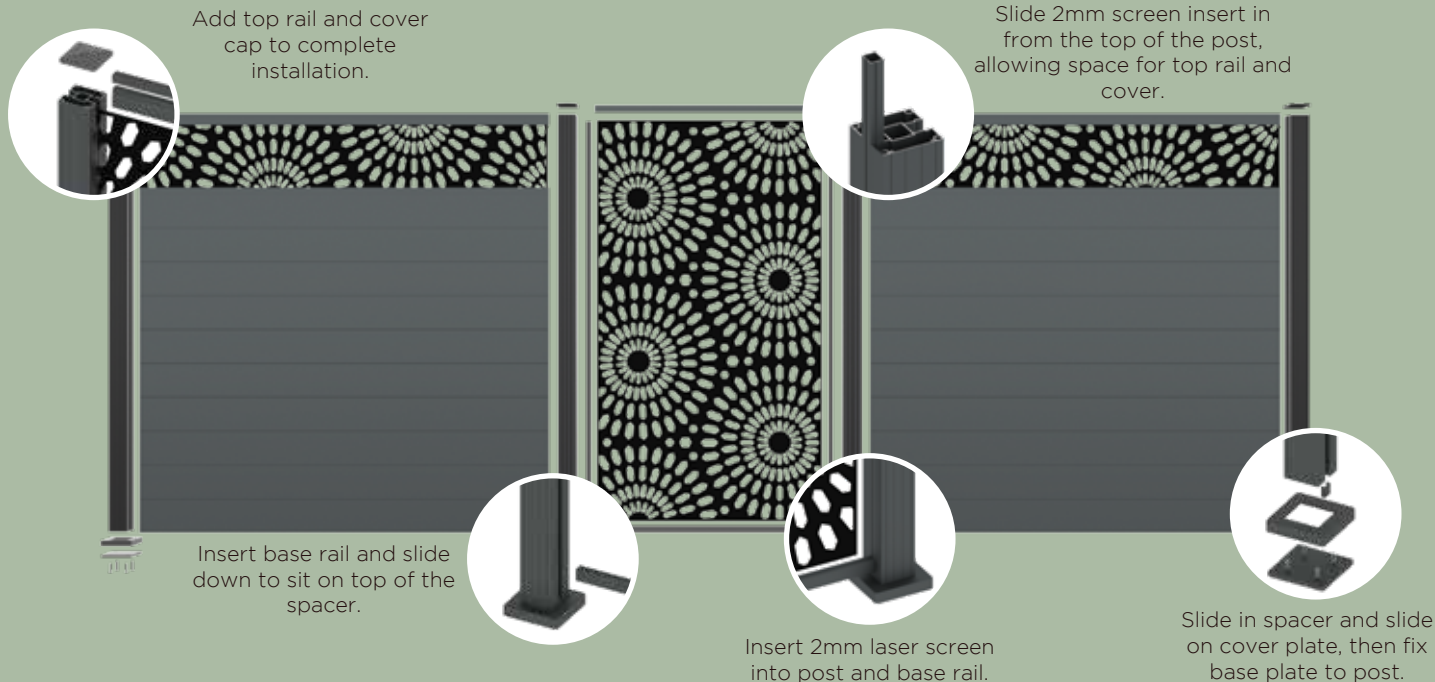

Add top rail and cover cap to complete installation.

Slide 2mm screen insert in from the top of the post, allowing space for top rail and cover.

Insert base rail and slide down to sit on top of the spacer.

Insert 2mm laser screen into post and base rail.

Slide in spacer and slide on cover plate, then fix base plate to post.



Palm Screens between Posts

# USING FULL HEIGHT LASER CUT SCREENS

We have a range of stunning designs in laser cut 2 or 5mm aluminium sheet, that are 300 x 1825mm, and 1000 x 1825mm. They are available powder coated in a Black Sand RAL 9005 long lasting UV resistant paint. They are secured into the Connect 150 system using the Laser Screen Fixing Kit.

**WOODLAND**

**PALM**

**SUNBURST**



WOODLAND



PALM



SUNBURST



# OVERVIEW OF POST FIXING SCENARIOS

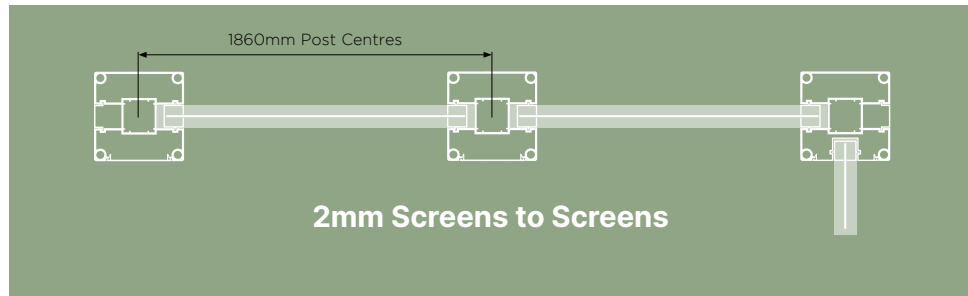
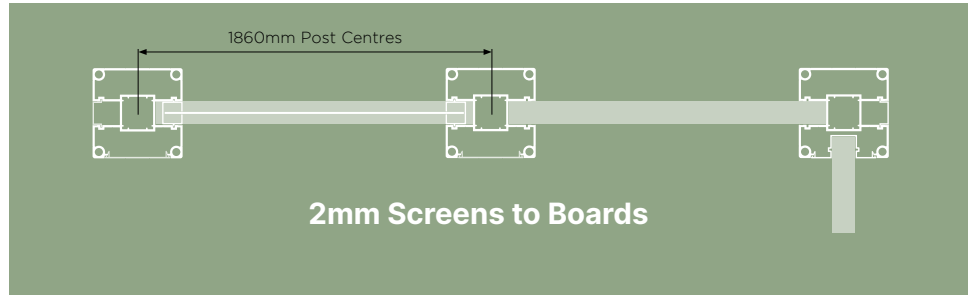
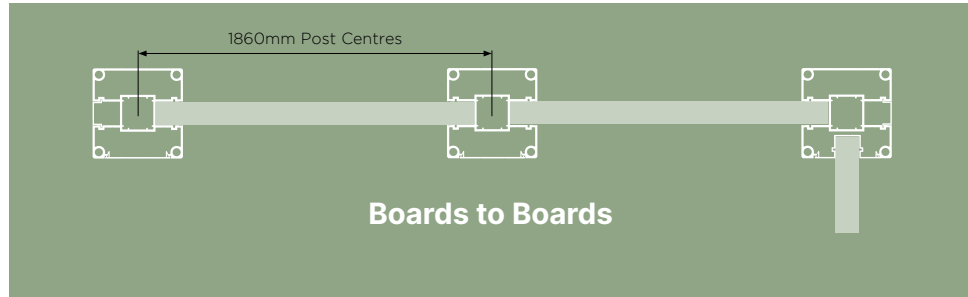



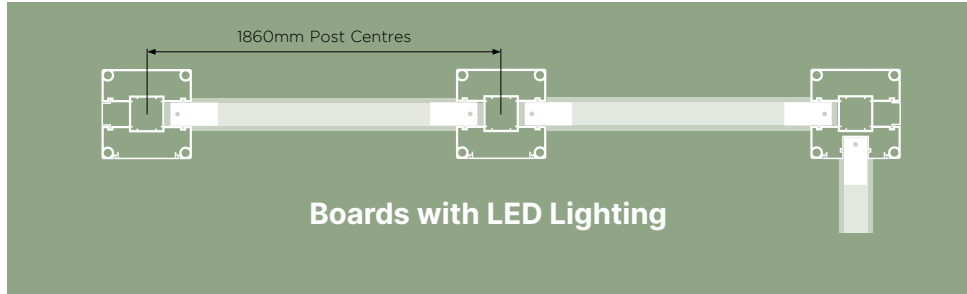
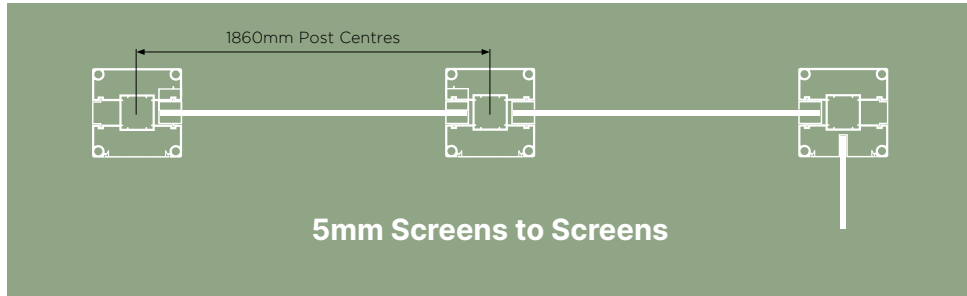
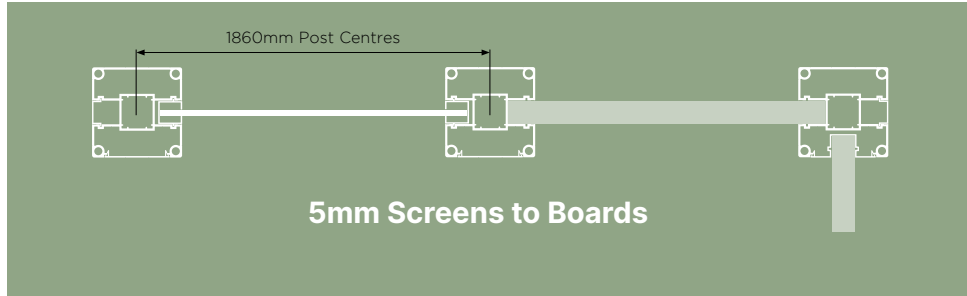

# *Illuminating Designs*

The latest addition to the Marano® Integrated range is the option to incorporate LED lighting into your fencing installation. Our waterproof LED system sits within the top and bottom channels, which simply run in between the posts, discretely hiding the LED strips to create a unique lighting system.



Ingress Protection

# IP65

Solid & Water Protection



Horizontal Ridged in Black Sand with LED Strip



Half Round in Basalt Grey Between Pillars



## BOARDS TO WALL

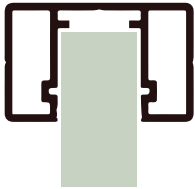

## 2mm SCREENS WITH FIXING KIT TO WALL

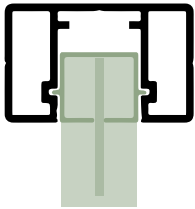

## 5mm SCREENS TO WALL

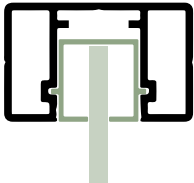

# RUN AGAINST WALLS & BUILDINGS

By using the highly versatile 1.86m high Wall Fixing Post (1), you can discreetly fix your fence onto a wall, brick pillar, steel or concrete posts. The fixings (2) are hidden in a cavity behind the boards. There is a small groove in the extrusion to help locate your drill or screw into the middle of the extrusion.

Boards (3) and spacers (4) are then slid into the wall fixing post.

The first board can be positioned and then secured from the rear facing side of the extrusion. Or you can screw or glue a cap (5) into the bottom of the wall fixing post, to raise the first board off the ground. To ensure that boards do not move, or cannot be lifted once installed, a screw can also be used in the top board.

Wall fixing posts can be cut to size for use on brick pillars and can also be inserted in existing concrete posts. Please buy additional post caps if required.

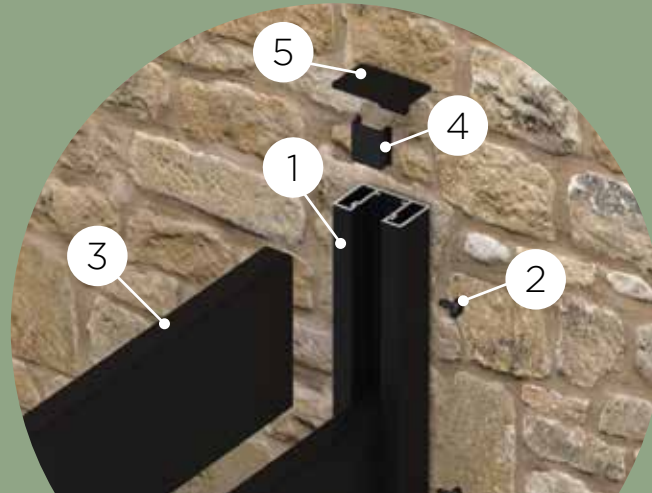

<b>Benefits</b>	<b>Wood</b>	<b>Aluminium</b>
Lightweight	X	✓
Low Maintenance	X	✓
Longevity	X	✓
Easy Installation	X	✓
Easy To Handle	X	✓
Aesthetic From Both Sides	X	✓
Sleek & Stylish Design	X	✓



Connect Board in Grey Wood Effect with Sunburst Screen

# REPLACE YOUR WOOD PANELS

Keep existing concrete posts and add our concrete post insert

## FINISHES

● Black Sand

● Basalt Grey



Upgrade your existing fence by removing those old wooden panels and replace them with our range of aluminium boards.

No need to replace the concrete posts or gravel boards, as you can use our versatile post insert which will fit discreetly into your existing post.

The 1.86m high post insert can also be cut to size to suit different fence heights.

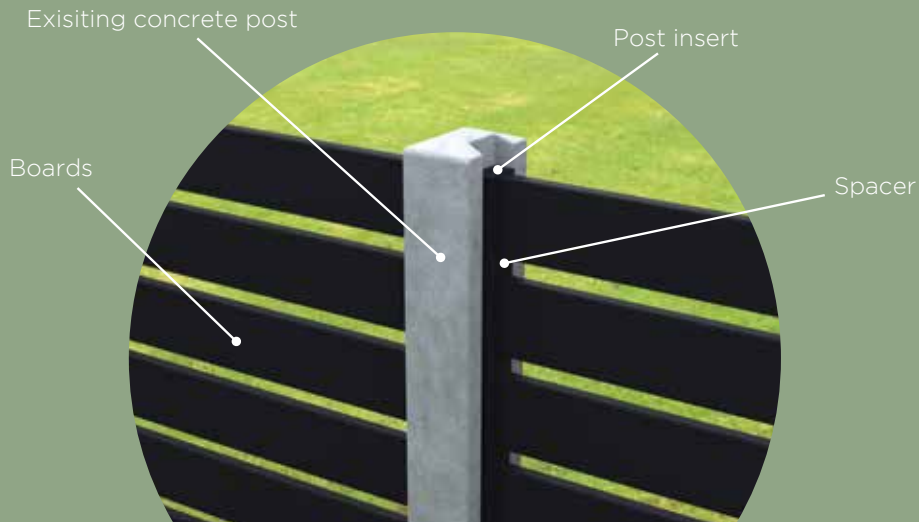





## BESPOKE GATES

We are pleased to offer steel framed gates with our Marano® aluminium boards.

These gates can be tailored to your exact requirements and seamlessly integrated with one of our many fencing systems, offering a total perimeter solution.



Bespoke Gates



Durable Steel  
Frame

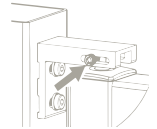

Invisible  
Hinges



Secure  
Integrated Lock

**6063  
T5**

Premium Grade  
Aluminium Boards



Match Gate to  
Fencing



Sleek &  
Stylish Design



Compatible with  
Marano Boards



Comes Fully  
Assembled



9





# liveconfigurator™



**Most Innovative Interior  
Design Software 2023**

**Award-winning  
configuring  
software**  
**The perfect tool for  
landscapers**

**1**



**STEP 1**  
Design &  
configure your  
project

**2**



**STEP 2**  
Receive your  
quote pack

**3**



**STEP 3**  
Place your order



Try for  
**Free**  
today!



Coming soon to LiveConfigurator...

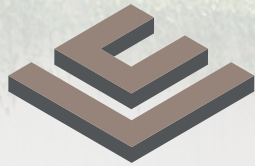

**live**configurator<sup>TM</sup>  
FENCING



***DESIGN YOUR GARDEN FENCE IN MINUTES!***

- 8 styles to choose from
- 4 matt finishes, 2 wood effect & mill finish (to powder coat to any colour)
- 3 styles of laser cut screen, in 2 sizes
- Boards can be integrated to create unique design
- Bolt-down or concrete-in

In the meantime, why not try configuring your:

**BALUSTRADES** - **STAIRWAYS** - **BESPOKE GLASS** - **DECKING**



MARANO

LIGHT • STYLE • VISION

[www.fhbrundle.co.uk](http://www.fhbrundle.co.uk)